



**BREAKER
TECHNOLOGY,
INC.**

An ASTEC COMPANY

CIRCULATE TO:
 Parts Manager
 Sales Manager
 Service Manager
 Customer Service

SERVICE BULLETIN

No.212

PRODUCT: TC90 & TC150 Compactors

Date: October 23, 2000

SUBJECT: Lattice Mounts, Retro-fit Kit 650-8755

EQUIPMENT AFFECTED: All TC90 and TC150 Compactors

CLASSIFICATION: Mandatory Safety
Mandatory Repair
Optional Repair
Fix-as-fail
Information

SITUATION: Engineering change to update the lattice mounts (from 650-8500 to 650-8752).

- SOLUTION:
1. Disconnect all hydraulic hoses from the hydraulic motor.
 2. Remove top mount (not shown) from the compactor. Keep the mounting hardware removed for reinstallation.
 3. Remove existing rubber lattices from the compactor.
 4. Attach adapter plate to studded rubber lattice assembly by applying Loctite 271 and torque to 220 ft-lbs in lubricated condition.
 5. Bolt new rubber lattice mounts and adapter plate to base using specified hardware, by applying Loctite 271 and torque to 280 ft-lbs in lubricated condition.
 6. Reinstall top mount to lattices using existing mounting hardware.
 7. Reconnect all hydraulic hoses, ensuring proper 'P' and 'T' connections.

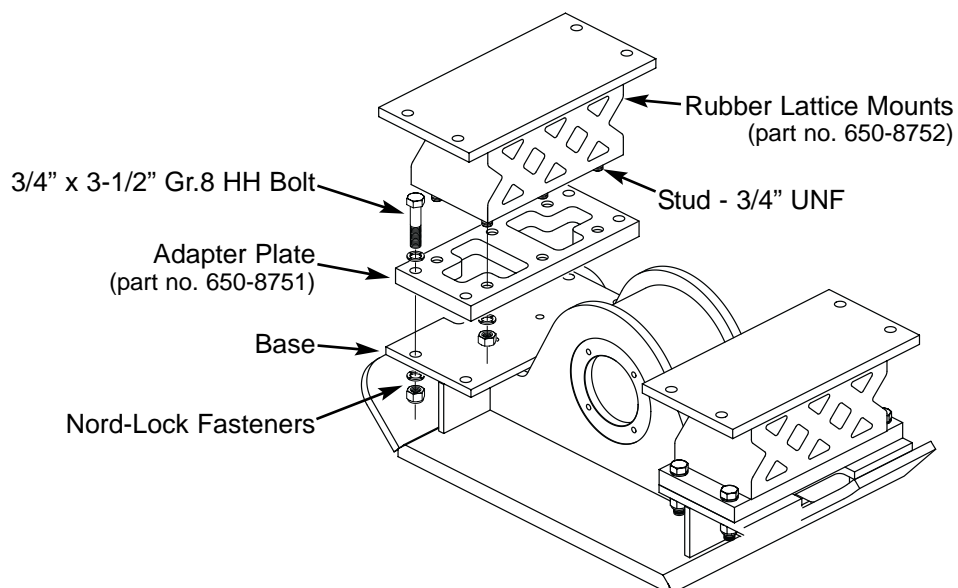

This product bulletin advises you of a product improvement/maintenance suggestion and does not imply that its contents are subject to a campaign program

